

Modular Cooking Range Line 700XP 3 Door Refrigerated Base

ITEM # _____

MODEL # _____

NAME # _____

SIS # _____

AIA # _____

371293 (E7TTCECOMKN)

Refrigerated base with 3 doors, +10-2°C, automatic evaporation of defrost condense - R290

Short Form Specification

Item No.

Refrigerated base with 3 doors. Built-in refrigerator compressor unit. Operating temperature range from -2°C to 10°C. To be installed below 700XP top units. To be delivered with 50 mm height adjustable feet. Exterior panels in stainless steel with Scotch Brite finish. One piece pressed work top in 1.5 mm thick stainless steel. Right-angled side edges to allow flush-fitting junction between units.

Main Features

- Unit can be easily installed below other 700 line top models.
- Adjustable temperature range from -2 °C to +10 °C to suit meat, fish and dairy storage requirements.
- Anti-tilt runners accept GN 1/1 containers.
- Forced air circulation for rapid cooling and an even temperature distribution.
- Right angled side edges eliminate gaps and possible dirt traps between units.
- Defrosting and automatic evaporation of condense drain: the condense is automatically evaporated thanks to the electric resistance in the condense drain container.
- Designed for modular installation into the cooking block.

Construction

- Exterior panels in Stainless steel with Scotch Brite finish to meet the highest hygiene standards.
- Built-in compressor to suit operating conditions.
- Access to all components from the front.
- Unit delivered with 150 mm height adjustable feet in Stainless steel. Feet can be extended up to 250 mm.

Sustainability



- CFC and HCFC free (highly ecological refrigerant type: R290).

Optional Accessories

- Flanged feet kit PNC 206136
- Frontal kicking strip for concrete installation, 1600mm PNC 206152
- Frontal kicking strip, 1600mm (not for refr-freezer base) PNC 206179
- Kit 4 feet for concrete installation (not for 900 line free standing grill) PNC 206210
- 2 panels for service duct for single "top on base" installation PNC 206248
- Pair of side kicking strips PNC 206249
- Pair of side kicking strips for concrete installation PNC 206265
- Kit 6 wheels - 3 swivelling with brake PNC 206432
- Kit to install refrigerated base on wheels (wheels to be ordered separately) PNC 206444
- Kit G.25.3 (NI) gas nozzles for 700 top and - freestanding on oven - gas cookers PNC 206460
- 2 side covering panels for free standing appliances PNC 216000

APPROVAL: _____

Front

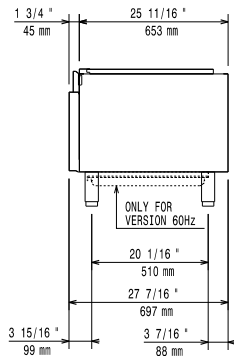

Side

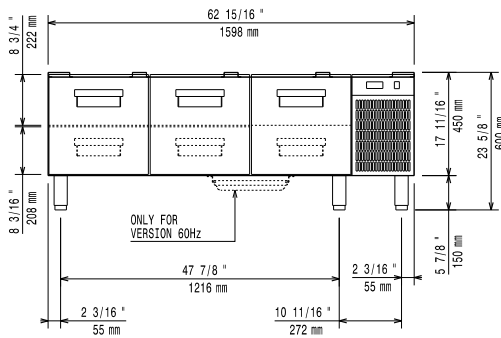

D = Drain
 EI = Electrical inlet (power)

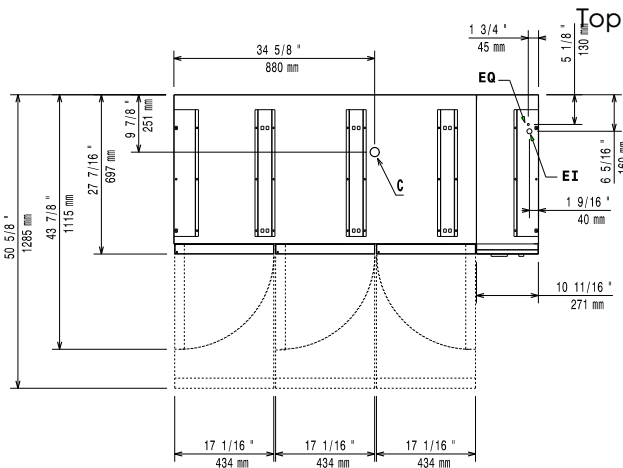

Electric

Supply voltage:	371293 (E7TTCECOMKN)	220-230 V/1N ph/50 Hz
Electrical power max.:		0.4 kW
Total Watts:		0.4 kW

Key Information:

Gross capacity:	240 lt
External dimensions, Width:	1600 mm
External dimensions, Depth:	700 mm
External dimensions, Height:	600 mm
Net weight:	110 kg
Shipping weight:	119 kg
Shipping height:	800 mm
Shipping width:	860 mm
Shipping depth:	1700 mm
Shipping volume:	1.17 m ³

Sustainability

Refrigerant type:	R290
Refrigerant weight:	85 g